

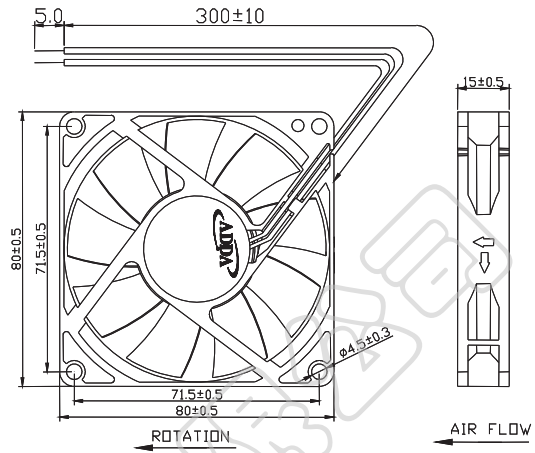

AG8015 SERIES

Preliminary

External Dimensions



Frame: Plastic (UL:94V-0)
 Impeller: Plastic (UL:94V-0)
 Lead wire: UL1007AWG24

Specifications(Nominal)

*Noise is measured at the distance of one (1) meter from the axis of intake.

Bearing type: ◎=Ball ※=Sleeve ○=1B1S ●=Hypro bearing

Frame size (mm)	Model No.	Bearing System Type	Rated Voltage (VDC)	Current (A)	Power (W)	Rated Speed (rpm)	Maximum AirFlow (CMM)	Maximum AirFlow (CFM)	Maximum Pressure (InAq)	Maximum Pressure (mmAq)	*Noise Level (dB/A)	Weight (g)
80x80x15	AG08012UB159000	◎	12	0.28	3.36	4000	1.325	46.82	0.248	6.30	42.5	63.0

Specifications subject to change without notice.

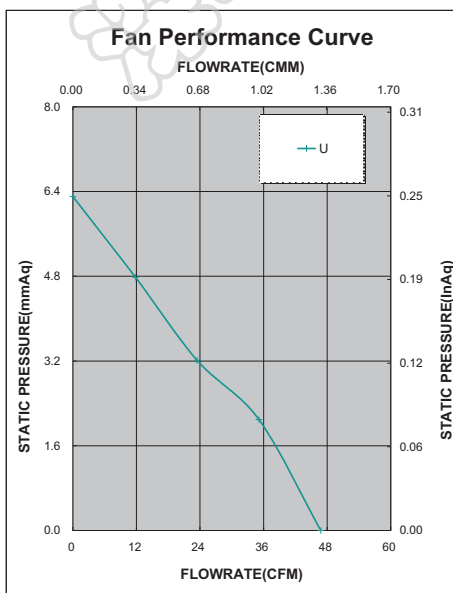

*Motor protective circuit and third lead wire functions

0	1	2	3	4	6	7	8	9	A	B
✓					✓					

*Safety approvals

				✓